



WL250

OPERATING, INSTALLATION, AND SERVICE MANUAL



Waterlogic Commercial Products, LLC
11710 Stonegate Circle
Omaha, NE 68164
(800) 288-1891
www.waterlogic.us

WL250 OPERATING, INSTALLATION, AND SERVICE MANUAL

Congratulations on your choice of the **Waterlogic WL250** water treatment system. The **WL250** model dispenses cold, and hot. Every **WL250** includes:



Bio-Cote Anti-Microbial Protection



Advanced In-Tank Ultraviolet (UV) Purification

The **Waterlogic WL250** provides exceptional quality and great tasting water with every use.

TABLE OF CONTENTS

• Features and Benefits	3
• Certifications	4
• Introduction and Safety Alert Symbols	5
• Safety Precautions	6
• Model and Part Designations.....	7
• Specifications	7
• Operating Instructions	8
• Hot Tank Principles of Operation.....	9
• Flow Diagrams.....	10
• Pre-Installation Procedures	12
• Draining Procedures.....	16
• Installation Procedures	20
• Service Requirements	22
• Replacement Components	23
• Hot Tank Descaling Instructions	24
• Resetting the Overload or High Limit Safety	26
• Layout Drawings and Part Lists.....	28
• Main Parts Drawings and Parts Lists.....	31
• Wetted Parts Drawing and Parts List	37
• Electrical Diagrams.....	38
• Fault Codes and Troubleshooting	40
• Warranty	60



WL250 FEATURES AND BENEFITS

Cold and Hot Water

Counter Top and Tower Models come standard with Cold and Hot Selections to meet a wide range of customer demands. The Tower Model is also available in Cold Only Water Version.

High Volume Storage and Water Capacity

Tower Model has 4 liters of Cold Water Capacity and 1.6 Liters of Hot Water Capacity. Counter Top has 2 liters of Cold Water Capacity and 1.6 Liters of Hot Water Capacity.

BioCote® Anti-Microbial Protection

Plastic surfaces surrounding dispensing areas and drip tray are infused with an exclusive silver additive called BioCote®. Silver is a natural anti-microbial that inhibits the growth of microorganisms providing additional surface protection.



Large Dispense Area with Recessed Faucet

8.5 inch dispense height with BioCote® recessed faucet to protect from cross-contamination.

Leak Detection

Counter Top Model is supplied with a Sensor in the Leak Tray that halts water supply to prevent overflow and sounds alarm to reduce accident potential.

Child Safeguard

WL250 requires Hot Water selection followed by main dispense for Hot Water, and defaults back to cold selection after 3 seconds of inactivity to prevent accidental dispensing of hot water.

In-Tank UV Purification

Industry leading In-Tank UV Purification prevents the growth of bio-film within the Stainless Steel Cold Tank.

Auxiliary Port

Auxiliary Port to feed Coffee Machines or other Appliances on Counter Top Models.



WL250 CERTIFICATIONS

Waterlogic water treatment systems have been tested, and certified to rigorous NSF and UL Standards. We believe that performance testing and certifications validate **Waterlogic** as a world-leader in water treatment systems.

WL250 Certifications Include



UL399 – Certified Drinking Water Cooler

Intertek Labs (ETL) Certified the WL250 to ANSI/UL 399 Standard for Drinking Water Coolers.



BPA Free - **Waterlogic** tests for BPA and declares that all of its products are Bisphenol-A FREE and contain no harmful BPA plastics.



NSF/ANSI-61 – Certified Drinking Water System Components

The **WL-250** has been tested and certified by The Water Quality Association (WQA) to NSF/ANSI-61, Section 9.

Waterlogic manufacturing is certified to ISO 9001 – Quality Management Systems (certified by Moody International). ISO 9001 is the internationally accepted standard for well managed organizations that have adopted the key quality management principles to its operations to bring consistent quality products and a culture of continuous improvement.



Safe Drinking Water Act

Waterlogic water treatment systems conform to the Safe Drinking Water Act (SWDA) “lead-free” amendment effective January 4, 2014.

INTRODUCTION

Carefully read and follow all instructions to ensure proper and efficient operation of your **WL250**. Contact **Waterlogic** or an **Authorized Waterlogic Dealer** if you have any questions.

Waterlogic and **Authorized Waterlogic Dealers** employ trained service personnel who are experienced in the installation, function and repair of **Waterlogic** equipment. This publication is written for use by these qualified individuals. **Waterlogic** encourages users to learn about products, however, we believe that product knowledge and service is best obtained by consulting **Waterlogic** or an **Authorized Waterlogic Dealer**.

Waterlogic water treatment systems should be combined with selected water treatment components to create a system specifically tailored for each application by trained and qualified personnel.

Products manufactured and marketed by **Waterlogic** and its affiliates are protected by patents issued or pending in the United States and other countries.

Waterlogic reserves the right to change the specifications referred to in this literature at any time, without prior notice. Changes or modifications not expressly approved by **Waterlogic** could void the warranty and user's authority to operate the equipment.

SAFETY ALERT SYMBOLS

Read and follow all safety information carefully. The signal words used in this manual are selected as shown below and based on an assessment of the degree of potential injury or damage (severe or minor) and the occurrence of injury (definitely occurs or has the potential to occur) when the warning is ignored:

 **DANGER!**

Indicates a situation which, when not avoided, results in death or severe injury.

 **WARNING!**

Indicates a situation which, when not avoided, has the potential to result in death or severe injury; and/or severe property damage.

 **CAUTION!**

Indicates a situation which, when not avoided, results or has the potential to result in minor injury; and/or minor property damage.

SAFETY PRECAUTIONS

Basic safety precautions should be followed, including the following:

⚠ DANGER! *If incorrectly installed, operated or maintained, this product can cause death or severe injury. Those who install, operate, or maintain this product should be trained in its proper use, warned of its dangers, and should read the entire manual before attempting to install, operate, or maintain this product.*

⚠ WARNING! *Unit is to be used for its intended purpose as described in this manual, and untrained individuals who use this manual assume the risk of any resulting property damage or personal injury.*

⚠ WARNING! **HOT WATER.** *Unit produces Hot Water up to 188°F. Water above 125°F can cause severe burns or scalding. Keep unauthorized people and children away from the unit to avoid accidental dispensing of hot water. Children should not use without supervision.*

⚠ DANGER! **ELECTRICAL SHOCK HAZARD.** *Always unplug from power supply prior to servicing equipment to prevent electrical shock.*

⚠ WARNING! *This system to be used for water only and is not intended for use where water is microbiologically unsafe or with water of unknown quality without adequate disinfection before or after the system. The system is designed for the supplemental bactericidal treatment of either treated and disinfected public drinking water, or other drinking water, which has been tested and deemed acceptable for human consumption by the state or local health agency having jurisdiction. The system is designed to reduce normally occurring non-pathogenic or nuisance microorganisms only. System is not intended for treatment of contaminated water.*

⚠ WARNING! **Dispenser Could Tip or Fall causing serious injury.** *Always install unit on a firm, flat, and level surface and secure the **WL250** to the base cabinet with the screw provided to lock the components together. Never place heavy items on top of unit and never climb, stand, or hang on unit or storage cabinet to prevent injury and damage.*

⚠ CAUTION! **INDOOR USE ONLY.** *Do not install outdoors or where unit is in direct sunlight. Do not install where ambient temperature goes below 50F or above 97F. Avoid high humidity and moisture. Product life and performance will be impacted and warranty could be voided.*

MODEL/PART DESIGNATIONS

BRAND NAME	DESCRIPTION	MODEL - PART NUMBER
WL250 Counter Top	<i>Waterlogic WL250 Counter Top</i> - Cold and Hot F-6002-M-HC-UT-CS-INN	12-CHCMU3
WL250 Tower	<i>Waterlogic WL250 Tower</i> - Cold and Hot F-6002-FS-HC-UT-CS-INN	12-CHCU3
WL250 Tower – Cold Only	<i>Waterlogic WL250 Tower</i> - Cold F-6002-FS-C-UT-CS-INN	12-CCU3

SPECIFICATIONS

ITEM	WL250 Counter Top	WL250 Tower
Water Connection	¼" Quick Connect	
Cold Water Temperature	Cold Water Temperature – Factory Set Point 41° - 5°C (Adjustable) 34° - 54° F. (1.1° - 12.2°C)	
Hot Water Temperature	189° F (87°C)	
Hot Water Manual Reset Overload	221° F (105°C)	
Recommended Service Pressure	40-60 psi (275-414 kPa) – Use Pressure Regulator	
Maximum Service Pressure	100 psi (689 kPa) – Use Pressure Regulator	
Rated Service Flow	0.5 gallons per minute (1.89 Lpm)	
Environmental Temperature	35° - 100°F (2° - 37°C)	
UV Lamp	4 Watts	8 Watts
Heater	500 W	
Refrigerant Gas	R134a, 40g, 1.41 ounces	R134a, 65g, 2.29 ounces
R134a Pressures	High (230 psi), Low (90 psi)	

SHIPPING SPECIFICATIONS

ITEM	WL250 Counter Top	WL250 Tower
Width/Depth/Height	13.5" x 14.5" x 17.75" [#] (34cm x 37cm x 45cm)	13.5" x 14.5 x 40.5" (34cm x 41cm x 103cm)
Weight (dry)	42 pounds (19.5 kg)	58 pounds (26.5 kg)

ELECTRICAL SPECIFICATIONS

ELECTRICAL SUPPLY	120V/60Hz, 1PH	15 Amp Service
COMPONENT	POWER (approximate)	AMP DRAW (approximate)
Heater	504	4.2 Amps
Compressor	216	1.8 Amps
UV Lamp System	18	0.15 Amps
WL250 TOTAL	738	6.15 Amps

#WL250 Counter Top is 17.75 in. tall and may not fit between countertops and cabinets - Check installation to ensure adequate clearance.

OPERATING INSTRUCTIONS



The above picture shows front LCD display and control panel for the **Waterlogic WL250**.

For Cold Water: Press Cold Water Select Button followed by the Dispensing Button (within 3 seconds).

For Hot Water: Press Hot Water Select Button followed by the Dispensing Button (within 3 seconds).

NOTE: Default selection mode is Cold Water. Selection will return to default after 3 seconds of inactivity.

NOTE: Selection indication light will turn red when the Hot Water Select button is pressed, and will switch back to the default green within 3 seconds after dispensing the hot water.

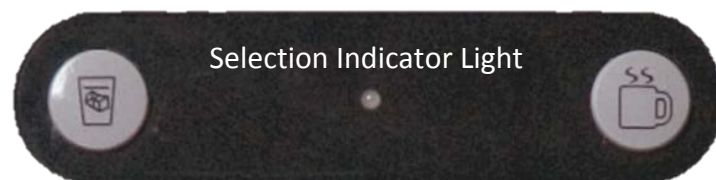

HOT TANK PRINCIPLES OF OPERATION

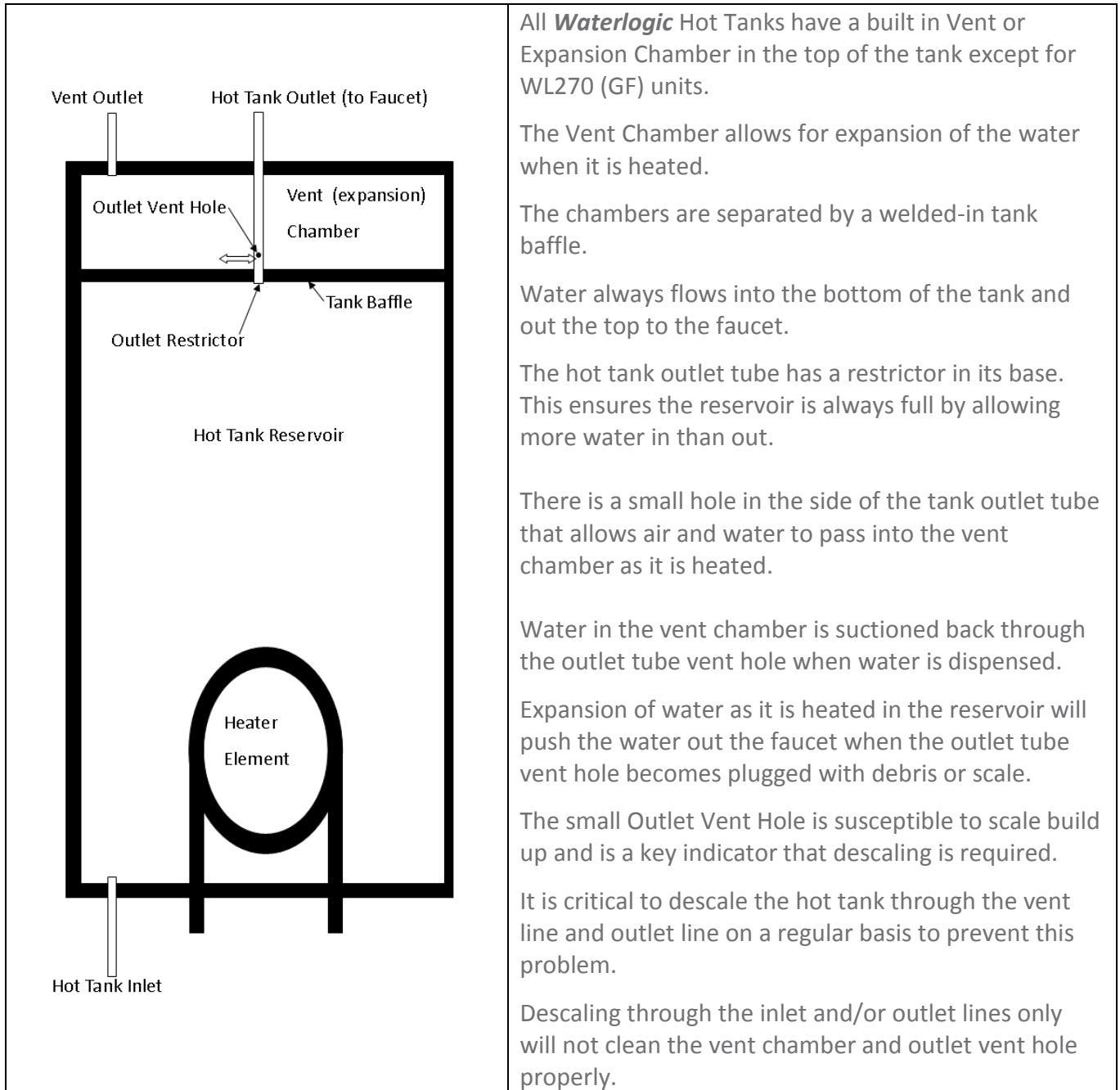

WL250 COUNTER TOP WATER FLOW DIAGRAM

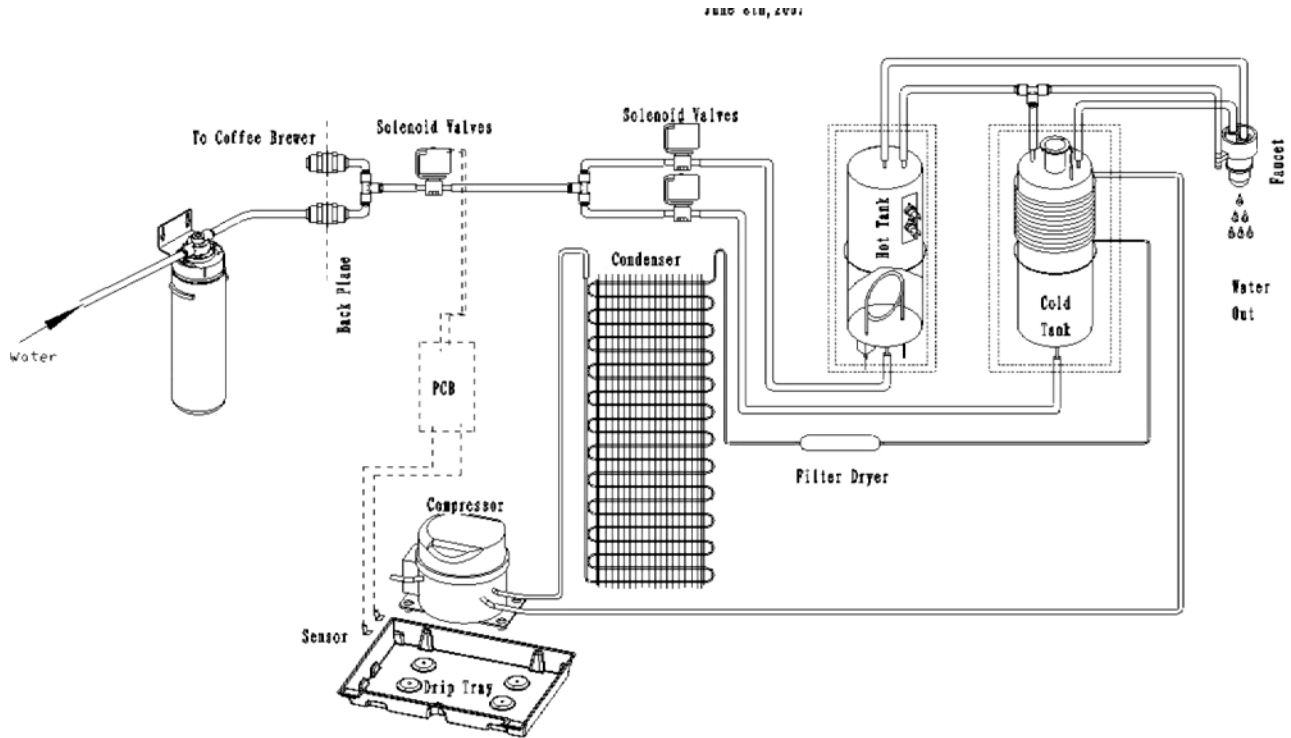

WL250 TOWER WATER FLOW DIAGRAM

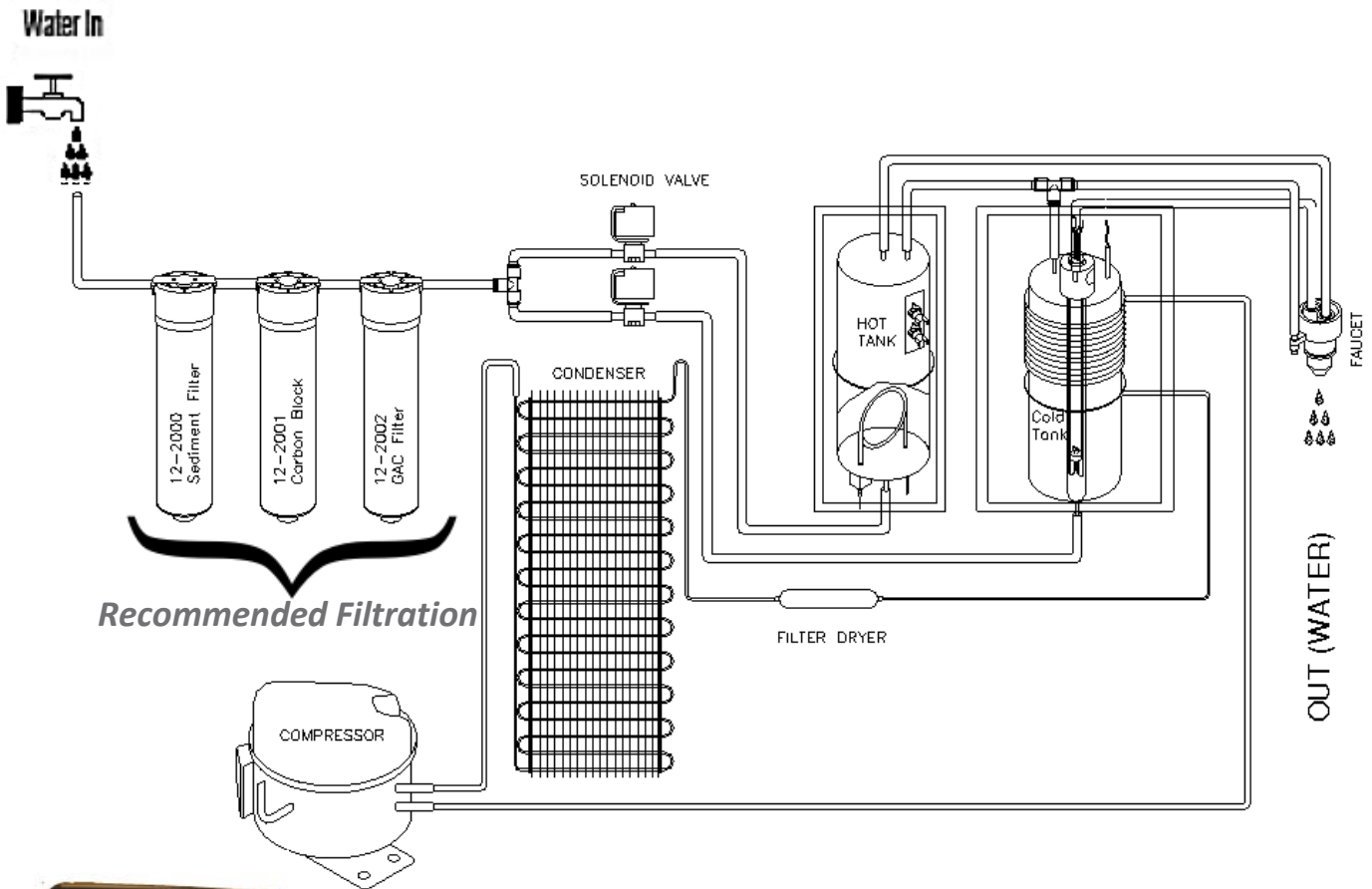

PRE-INSTALLATION PROCEDURES

⚠ DANGER! ELECTRICAL SHOCK HAZARD.

Only qualified personnel who have read and understand this entire manual should attempt to install, or service this unit, failure to do so could result in death or serious injury. DO NOT plug into an electrical supply until specifically instructed.

⚠ WARNING! ALWAYS SANITIZE BEFORE USE.

Sanitize before use to eliminate any potential microbiological contaminants.

Materials Needed:

- Personal Protective Equipment. Rubber or Nitrile Safety Gloves and Protective Eyewear
- Phillips Screwdriver
- Temperature Gage
- Water Pitcher or Container to collect water from the faucet
- 5 gallon container or drain basin
- Sanitizer - Household Bleach (5.25% Sodium Hypochlorite) or Citric Acid Based Cleaner
- ¼" Plastic Tubing, at least 4 feet in length, and assorted ¼" quick connect fittings
- TDS Meter and Test Strips for measuring chlorine - Optional

1. Unpack the **Waterlogic WL250** and check exterior for damage.

Flush Filters

⚠ CAUTION! FILTER FLUSH REQUIRED.

WL250's are not supplied with filters. Filters should be configured to optimize your system...Filters need to be configured and specified to do the job given the local water conditions, usage, maintenance schedule, and placement restrictions.

In order for our filters to perform as represented and to provide the best quality water possible, it is essential that filters be replaced periodically. The frequency of filter changes depends upon your water quality and your water usage. For example, if there is a lot of sediment and/or particles in your water, then you will have to change your filters more frequently than a location with little to no sediment. Be sure to replace your filters whenever you notice a decline in the performance, whether it is a drop in flow rate and/or pressure or an unusual taste in the water.

2. Flush thoroughly per filter manufacturers' recommendation with fresh water to drain.
3. Once flushed, install the filters. Following the flow direction on the filter.

NOTE: Filters should not be flushed prior to 24 hours before installation to limit Microbial Growth.

Sanitizing

Sanitize using a Household Bleach (5.25% Sodium Hypochlorite solution) or other approved cleaner throughout the cold and sparkling water circuits. Follow all instructions on the sanitizer and flush with fresh water through the faucet until odor and taste is acceptable.

⚠ WARNING! USE PROPER PERSONAL PROTECTIVE EQUIPMENT

Always ensure proper ventilation and use proper personal protective equipment such as gloves and eye protection when using chemicals. Refer to Material Safety Data Sheet for specific requirements of each chemical product. Take all necessary precautions to prevent sanitizer from contacting eyes, clothing, and any other surfaces in could damage (carpets).

4. Disconnect the UV Lamp wiring harness and carefully remove the UV Lamp from the quartz sleeve.

⚠ CAUTION! UV SYSTEM IS FRAGILE. *Never handle the UV System with bare hands. UV Lamp and quartz sleeve must be free of oils contaminants to ensure proper operation.*



and

5. Unscrew cold tank/quartz sleeve retaining cap and remove the quartz sleeve. This will require top cover to be removed to access properly and facilitate removal.
6. Mix ½ gallon of sanitizer per directions or use Bleach Solution (1 teaspoon = 1/6 oz. = 5 ml = ½ cap full) of household bleach (Sodium Hypochlorite 5 - 10% Concentration) with 1/2 gallon of water. Always ensure sanitizer is compatible with stainless steel and acetyl plastic.
7. Pour sanitizer solution into cold tank thru funnel or spout. You may add concentrated sanitizer (½ cap bleach) directly into empty cold tank instead of premixing.
8. Inspect and clean quartz sleeve and O-ring. Reinstall the quartz sleeve and quartz sleeve retaining nut. Tighten firmly to ensure proper seal. Over-tightening can cause damage.

⚠ CAUTION! DO NOT INSTALL THE UV LAMP AT THIS TIME

The UV will interact with the sanitizer and could potentially cause taste.

9. Connect 40-60 psi regulated, potable water supply to the water inlet bulkhead fitting located on the back of the unit. Turn on water supply and check for leaks.

⚠ DANGER! ELECTRICAL SHOCK HAZARD.

Do not plug in unit unless qualified. Only qualified personnel who have read and understand this entire manual should attempt to install or service this unit.

10. Connect **WL250** to power.

⚠ CAUTION! *NEVER TURN ON HEATER BEFORE FILLING HOT TANK.*

Red Heater and Compressor Power Switch must be in the O=OFF position while the hot tank is empty. Damage could occur within one minute and the overload (high limit) will require manual reset if heater is turned on with an empty hot tank.



Fill the Cold Circuit with Sanitizer

11. Depress the main dispensing button on the front control panel until cold water/sanitizing solution comes out the faucet. **NOTE:** Container and drain basin will be required to catch the water from the faucet.

⚠ WARNING! *Use Personal Protective Equipment. Gloves and Eye Protection Required. The first 2 or 3 gallons of water will contain concentrated sanitizer. Use extreme care!*

Flushing the Sanitizer from the Machine

12. Place a pitcher, catch basin, or other container under the faucet of the **WL250**.

13. Flush the Cold Tank. Run several gallons of water through the faucet by dispensing cold water to dilute and remove the sanitizer from the cold circuit. You can use chlorine test strips to evaluate the water.

14. Once the sanitizer odor/taste has been flushed out of the cold side of the machine the sanitization process for the Cold Circuit is complete.

Fill the Hot Tank

15. Press the Hot Water Select Button, followed by the main dispensing button to fill the hot tank. Water will dispense from the faucet once the hot tank is full. Flush until water is clear.

⚠ WARNING! *HOT CIRCUIT IS NOT SANITIZED.*

Water in the hot circuit is not sanitary until the temperature exceeds 171°F for at least 5 minutes.

UV System Functional Test

⚠ WARNING! *ULTRAVIOLET RADIATION. Protect your skin and eyes against ultraviolet rays. Never look directly at an operating UV light. Disconnect wiring before removing.*

16. Reinstall the UV Lamp and connect the wiring.

17. Dim or shield the overhead lights and peer into the machine, on top of the cold tank, at the UV connector and retaining cap. The blue glow indicates that the lamp is lit.

Compressor Test

18. Switch Red Compressor / Heater to *I=ON position*. Always ensure tanks are full of water before turning on the heater or the overload (high limit) will open and require manual reset. If the wire condenser at back of the unit is warm, the refrigeration system is working.



19. Once the machine reaches its target temperature, the compressor will shut off. Draw a glass of cold water and verify it has been chilled to proper temperature.

Heater Test

20. Always ensure tanks are full of water before turning on the heater or the overload (high limit) will open and require manual reset. It will take the heater approximately 10 minutes to heat the water from ambient 75°F to the factory set point of 185°F. Dispense a cup of hot water to ensure the temperature/odor/taste is acceptable.

⚠ WARNING! VERY HOT WATER CAN BURN OR SCALD.

Hot water should be dispensed carefully into insulated container to avoid injury.

WL250 COUNTER TOP DRAINING INSTRUCTIONS

Draining Notes

Drain the **WL250** for transportation.

⚠ WARNING! STORE UNIT EMPTY. ALWAYS SANITIZE BEFORE REUSE.

The unit must be completely drained and sealed before storing to avoid stagnation and reduce microbial growth).

Prior to draining the hot tank, turn off the Red Heater and Compressor Power Switch, and dispense 2 liters of hot water from the machine. As hot water is dispensed from the faucet of the unit, colder water will be introduced into the hot tank. Since the Red Heater and Compressor Power Switch is turned off, the heater will not energize and heat the incoming tap water. Following this precaution prevents exposing personnel and equipment (drains, catch basin, etc.) to scalding hot water.

Disable Cold and Hot Tanks

1. Turn off the Red Heater and Compressor Power Switch to disable the heater and compressor.
2. Dispense 2 liters of water through the hot tank to cool the water temperature in the hot tank and avoid burns.

⚠ WARNING! VERY HOT WATER CAN BURN OR SCALD.

Hot water should be dispensed carefully into insulated container to avoid injury.

Turn off Water Supply and Bleed Water Pressure

3. Isolate the unit from feed water by turning off the supply.
4. Dispense cold still water to relieve any pressure built up in the system.
5. Remove the water supply line from the inlet line bulkhead fitting at back of machine.
6. Install dust cap or plug into water supply line bulkhead fitting.

Drain the Cold Water Tank and Circuit

7. Remove top cover.

8. Remove front panel. Remove 2 Phillip screws securing front panel. Unseat faucet assembly from panel. Unclip wires from PCB.

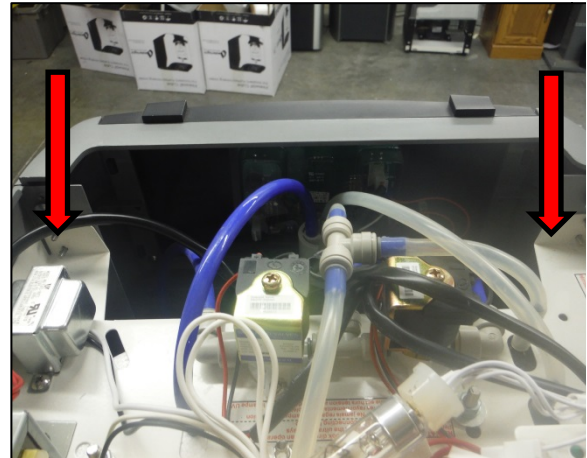

9. Disconnect tubing from inlet elbows on both solenoids and allow water to drain.

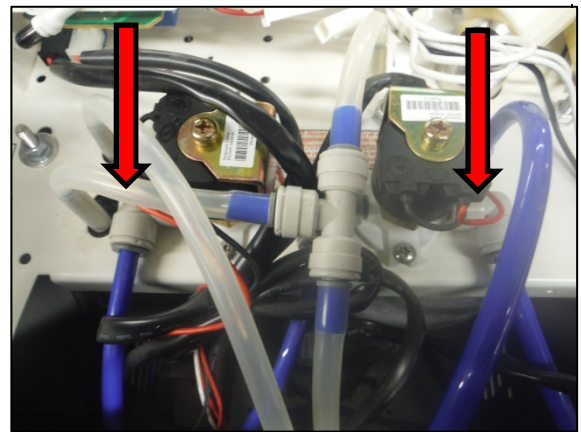

10. Reconnect tubing into inlet elbows.



11. Dry inside of unit.

12. Replace front panel.

WL250 TOWER DRAINING INSTRUCTIONS

Draining Notes

Drain the **WL250** for transportation.

⚠ WARNING! *STORE UNIT EMPTY. ALWAYS SANITIZE BEFORE REUSE.*

The unit must be completely drained and sealed before storing to avoid stagnation and reduce microbial growth).

Prior to draining the hot tank, turn off the Red Heater and Compressor Power Switch, and dispense 2 liters of hot water from the machine. As hot water is dispensed from the faucet of the unit, colder water will be introduced into the hot tank. Since the red power switch is turned off, the heater will not energize and heat the incoming tap water. Following this precaution prevents exposing personnel and equipment (drains, catch basin, etc.) to scalding hot water.

Disable Cold and Hot Tanks

1. Turn off the Red Heater and Compressor Power Switch to disable the heater and compressor.
2. Dispense 2 liters of water through the hot tank to cool the water temperature in the hot tank and avoid burns.

⚠ WARNING! *VERY HOT WATER CAN BURN OR SCALD.*

Hot water should be dispensed carefully into insulated container to avoid injury.

Turn off Water Supply and Bleed Water Pressure

3. Isolate the unit from feed water by turning off the supply.
4. Dispense cold still water to relieve any pressure built up in the system.
5. Remove the water supply line from the inlet line bulkhead fitting at back of machine.
6. Install dust cap or plug into water supply line bulkhead fitting.

Drain the Cold Water Tank and Circuit

7. Remove lower front panel to access tank feed lines.

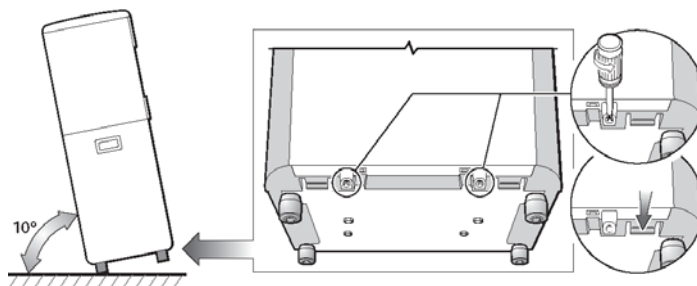

8. Disconnect tank line feed lines from hot and cold inlet solenoids to drain into basin or catch.

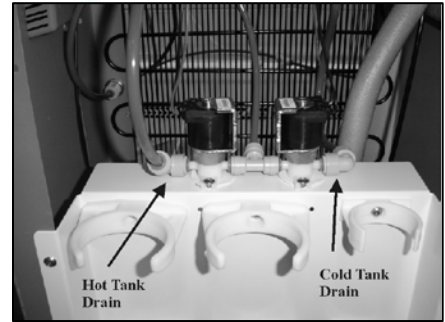

9. Reconnect tubing into inlet elbows once drained.

10. Dry inside of unit if necessary.

11. Replace lower front panel.

INSTALLATION PROCEDURES

Safety and Installation Guidelines

Ensure all Local, State, and Federal Laws and Codes including health and safety guidelines are met when installing **Waterlogic** Equipment. Only qualified service technicians should attempt installation and service of **Waterlogic** Equipment.

⚠ WARNING! ELECTRICAL SHOCK HAZARD. Always unplug (isolate from power supply) to prevent electrical shock except where electrical tests are specified.

⚠ WARNING! IMPROPER SUPPLY OR CONNECTION CAN RESULT IN RISK OF SHOCK. Connect to a 15 amp 120V 60Hz properly grounded outlet (GFI is recommended). Ensure polarity is correct and always use a 3-prong outlet. Consult a qualified electrician if you have any questions.

⚠ WARNING! USE ONLY Waterlogic SUPPLIED POWER CORD. Locate system within 5 feet of power supply. Never use an extension cord or adapter. Do not use a damaged power cord or plug. Keep power cord out of heavy traffic areas and away from heat sources. Do not, under any circumstances, remove ground prong or alter the power cord. Never pull the power plug from the outlet with a wet hand or allow the plug to get wet. Failure to use the supplied power cord will void UL Certification and Warranty.

⚠ CAUTION! INDOOR USE ONLY. Never expose to direct sunlight, heat sources, or ambient air temperature above 100°F (37°C) or below 35°F (2°C). Install indoors and keep unit away from excessive humidity. Never expose to freezing temperatures. Ensure there is adequate clearance around the unit to allow refrigeration system condenser to dissipate heat. Warmer environments require more clearance around the unit. Minimum clearance around all surfaces of the machine is 2-inches. Installs where the ambient temperature exceed 80F, require a minimum of 4-inches clearance for proper heat dissipation and efficient operation.

⚠ CAUTION! USE A WATER PRESSURE REGULATOR. **Waterlogic** will not be responsible for injury or damage caused by excessive water pressure. Operating pressure must be 40 psi to 60 psi. Be aware any of potential pressure surges caused by building/municipal pumping stations.

⚠ CAUTION! USE UV STABILIZED SUPPLY LINES. Feed the unit with a potable ambient or cold water supply only. Feed water over 100° F (37°C) can damage the treatment components. Water block devices and external leak detectors are strongly recommended. Locate the unit as close to the water supply and the electrical connections as possible.

⚠ WARNING! STORE AND TRANSPORT UNIT EMPTY. ALWAYS SANITIZE BEFORE USE. The unit must be completely drained and sealed before storing to avoid stagnation and reduce microbiological contamination (potential bacterial growth). Sanitize before use to eliminate any potential microbiological contaminants

Pre-installation and sanitization procedures as prescribed in this manual must be performed before installing the **WL250**.

Always install indoors and place the **Waterlogic WL250** on a firm, flat and stable surface.

1. Attach the water supply line to the 1/4" feed water inlet bulkhead fitting on the back of the unit. **Waterlogic** requires the use of a water pressure regulator. Water feed pressure must be between 40-60 psi. Turn on the water supply and check for leaks.

2. Check to ensure that the Red Heater and Compressor Power Switch is the O=OFF position.



NOTE: Switches have internal LED that illuminates when placed in I=ON position.

3. Connect the power cord to the back of the **Waterlogic WL250** and to a 120 Volt supply.

4. Fill the Cold Tank. Hold a container under the dispensing faucet, press and hold the main dispensing button until a continuous flow of water is obtained. Once a continuous flow is obtained, release the dispensing button. Cold tank is now full.

5. Fill the Hot Tank. Hold a container under the dispensing faucet. Press the Hot Select Button followed by the main dispensing button until a continuous flow of water is obtained. Once a continuous flow is obtained, release the main dispensing button. Hot tank is now full.

⚠ CAUTION! NEVER TURN ON HEATER BEFORE FILLING HOT TANK.

Red Heater and Compressor Power Switch must be in the O=OFF position while the hot tank is empty. Damage could occur within one minute and the overload (high limit) will require manual reset if heater is turned on with an empty hot tank.

6. Verify that the UV lamp operates as expected.

⚠ WARNING! ULTRAVIOLET RADIATION. *Protect your skin and eyes against ultraviolet rays. Never look directly at an operating UV light. Always disconnect before removal.*

7. Move the **Waterlogic WL250** into its final operating position. Be sure that a minimum of 2" clearance is maintained around both the sides and the back of the unit. This is important to allow proper airflow and heat exchange of refrigeration system.

8. Level unit using the adjustable feet to level if necessary. Never install on incline.

9. Turn the Red Heater and Compressor Power Switch to I=ON position.

10. When the unit has reached its Hot Temp Set Point, the heater will cycle off. When the unit has reached its Cold Temp Set Point Temperature, the compressor will cycle off.

11. Once the unit is at the target temperature(s), sample the water to ensure water meets expectations and additional rinsing or adjustment is not required.

12. Check the unit for any leaks. External Leak Protection is always recommended.

SERVICE REQUIREMENTS

⚠ WARNING! *Read and understand the contents of this manual before attempting to service WL250. Failure to follow the instructions in this manual could result in death, serious personal injury, or severe property damage. Only trained and qualified technicians should attempt to install, maintain, or service Waterlogic Equipment.*

1. Visually inspect all electrical and water connections for signs of wear or damage.

⚠ DANGER! *HIGH VOLTAGE ELECTRICAL HAZARD. Unplug before inspection and service.*

2. **Waterlogic** recommends changing the UV Lamp every 12 months.

NOTE: When replacing the UV lamp the wiring harness must also be replaced.

NOTE: The Glow Starter shown to the right, may appear blackened which is normal.



⚠ WARNING! *ULTRAVIOLET RADIATION. Protect your skin and eyes against ultraviolet rays. Never look directly at an operating UV light. Disconnect before removing UV Lamp.*

⚠ CAUTION! *UV LAMPS ARE HAZARDOUS. Lamps are considered Hazardous Waste and must be disposed of accordingly. Refer to Product MSDS sheet for details.*

3. Clean the quartz sleeve that surrounds the UV lamp with a non-abrasive cloth, descaling solution, or ultrasonic bath if needed when changing UV lamps.

⚠ CAUTION! *UV SYSTEM IS FRAGILE. Never handle the UV lamp or Quartz Sleeve with bare hands. UV Lamp and quartz sleeve must be free of oils and contaminants to ensure proper operation. Use a soft non-abrasive cloth to clean.*

4. Inspect the Quartz Sleeve O-ring for wear or damage and replace as necessary.
5. Ensure there is adequate (minimum of 2") clearance around the unit and clean the condenser grill and compressor fan to provide efficient cooling system operation.
6. Sanitize the cold tank per instructions in the pre-installation procedures.
7. Clean and sanitize external surfaces of the unit. Use soap and water or chemicals that are compatible with ABS plastic and will not damage or degrade the product surfaces.
8. Remove and clean the Faucet. Replace as needed.

⚠ WARNING! *SANITIZER MAY CONTAIN HAZARDOUS CHEMICALS. Use of proper personal protective equipment such as rubber gloves and eye protection is required.*

REPLACEMENT COMPONENTS

Component	Part No.	Frequency of Replacement
UV Light, 4 Watts – Counter Top	CT-2030	Every 12 months, or as required WLUSA Part No 12-2350
UV Quartz Sleeve – Counter Top	CT-2026	Clean every 12 months, replace as needed WLUSA Part No 14-1051
UV Light, 8 Watts - Tower	CT-2083	Every 12 months, or as required WLUSA Part No. – 10-2350
UV Quartz Sleeve - Tower	CT-2002	Clean every 12 months, replace as needed WLUSA Part No. 10-1400
Black Quartz Sleeve O-Ring	CT-2006	Each time Quartz Sleeve is replaced WLUSA Part No 10-2500
Hot Tank (87°C - 189°F) – Counter Top	HT-3018-A	Replace every 5 years WLUSA Part No 12-1406
Hot Tank (87°C - 189°F) - Tower	HT-3018	Replace Every 5 Years WLUSA Part No 12-1405

Replacement parts can be obtained from *Waterlogic* or an *Authorized Waterlogic Dealer*. See Parts Layouts, Drawings, and Lists for additional repair parts.

Hot Tank Service

Hot Tanks (with controls) must be replaced at least every 5 years. Descaling hot tank may be required on a regular basis depending upon filtration and local water conditions. See Service Section.

NOTE:

At the **end of this product's life**, ensure that it is disposed of in an environmentally friendly manner which is fully compliant **with all Federal/State/Local Requirements and Guidelines**.

HOT TANK DESCALING INSTRUCTIONS

The hot tank requires removal of mineral deposits (descaling) on a regular basis. Typically descaling should take place every 6 to 12 months to preserve the long-term health of your unit.

Use non-toxic cleaner such as ScaleKleen, DEZCAL, 20% Citric Acid Solution, or Undiluted Vinegar Solution to remove mineral deposits as directed by the manufacturer depending upon filtration and local water conditions.

Descaling is an important process that removes calcium deposits, or scale, that can build up inside a tank over time. Calcium and scale is non-toxic but left unattended will hinder your unit's performance.

⚠️ WARNING! ***PERSONAL PROTECTIVE EQUIPMENT REQUIRED.** Always ensure proper ventilation and use rubber or nitrile gloves and eye protection when using chemicals. Refer to Material Safety Data Sheet for specific requirements of each product.*

⚠️ CAUTION! ***STAINLESS STEEL TANK DESCALING.** The hot tank is made from stainless steel. Ensure descaling solution is compatible with stainless and always flush the unit completely. Dispose in an environmentally safe manner.*

Materials Needed:

- Personal Protective Equipment. Rubber or Nitrile Safety Gloves and Protective Eyewear
 - Phillips Screwdriver
 - Temperature Gauge
 - Water Pitcher or Container to collect water from the faucet
 - 5 gallon container or drain basin
 - Citric Acid Based Cleaner
 - ¼" Plastic Tubing, at least 4 feet in length, and assorted ¼" quick connect fittings
 - Sanitizing Cartridge
 - Food Coloring
1. Put descaler per directions and 3 drops of food coloring into the descaling cartridge.
 2. Connect descaling cartridge to the inlet water supply and connect to inlet bulkhead fitting on the back of the unit. Turn on Water Supply.
 3. Select Hot Water and depress the Main Dispensing Button on the Front Control Panel until descaling solution (colored water) comes out of the faucet. Container and drain basic will be required to catch water from the faucet.
 4. Turn off water supply and remove sanitizing cartridge from inlet water supply. Reconnect water supply to inlet fitting.



5. Allow descaling solution to remain in the Hot Tank for 15 minutes (length of time may vary depending on water conditions).
6. Place a pitcher, catch basin or other container under the faucet of the **WL250**.
7. Flush the Hot Tank until water runs clear.
8. Once clear Water dispenses from the faucet the Hot Tank has been descaled. Always ensure unit is performing to the customer's satisfaction.



⚠ WARNING! HOT WATER HAZARD. *Unit Produces Very Hot Water and Steam. Always use insulated and chemically compatible containers and let unit cool down before draining the hot tank to avoid injury.*

⚠ CAUTION! MUST REPLACE HOT TANK 5 YEARS. *The hot tank and its controls must be replaced a minimum of every five years to ensure efficient and dependable operation.*

⚠ WARNING! REINSTALL ALL PANELS AND COVERS. *Always reinstall all panels, protective covers, and fasteners after servicing equipment. Failure to do so could result in severe personal injury and will void the certifications and warranty of the equipment.*

RESETTING THE OVERLOAD OR HIGH LIMIT SAFETY

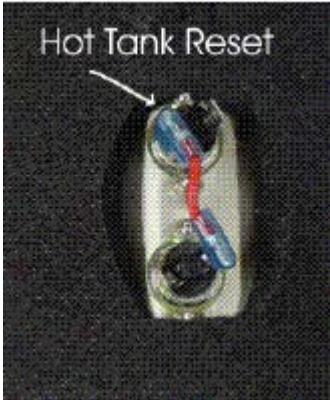
1.	<p>Turn off Red Heater and Compressor Power Switch on rear of unit.</p>	
2.	<p>Unplug the Power Cord from rear of unit.</p>	
3.	<p>Remove the Lower Front Panel of unit by removing the Phillips head screws underneath the lower front panel.</p>	
4.	<p>Locate the protective metal box on the rear of the hot tank. As you look through the condenser coils on the rear of the unit, you will see the hot tank located on the right hand side.</p>	
5.	<p>From the front of the Water Treatment System, reach up behind the hot tank and take hold of the protective metal box covering the thermostat and overload on the hot tank.</p> <p>There are nuts that secure the metal box to the hot tank. However the nuts are loose enough to allow you to remove the metal box.</p> <p>If the nuts on the metal box are too tight, loosen the nuts securing the hot tank to the upper base of the unit and lower the hot tank so you can remove the metal box.</p> <p><i>For demonstrative purposes, photos below have lowered the hot tank from the unit.</i></p>	

6.	<p>Press the reset button</p>  <p>The image shows a white rectangular button with a red reset button in the center. A white arrow points to the red button. The text 'Hot Tank Reset' is printed above the button.</p>  <p>The image shows a person's hand using a pair of orange-handled pliers to press the red reset button on a hot tank unit.</p>
7.	<p>Reattach the metal box by depressing the top flap of the metal box so it snaps back into its original position on the hot tank.</p>
8.	<p>Replace the Lower Front Panel on unit using Phillips head screws.</p>
9.	<p>Plug in the Power Cord.</p>
10	<p>Make sure the hot and cold tanks are filled with water BEFORE turning on the Red Heater and Compressor Power Switch</p> <p>Verify the cooler is fully operational before installing it at the customers' site.</p>

WL250 COUNTER TOP LAYOUT DRAWING with PART NUMBERS

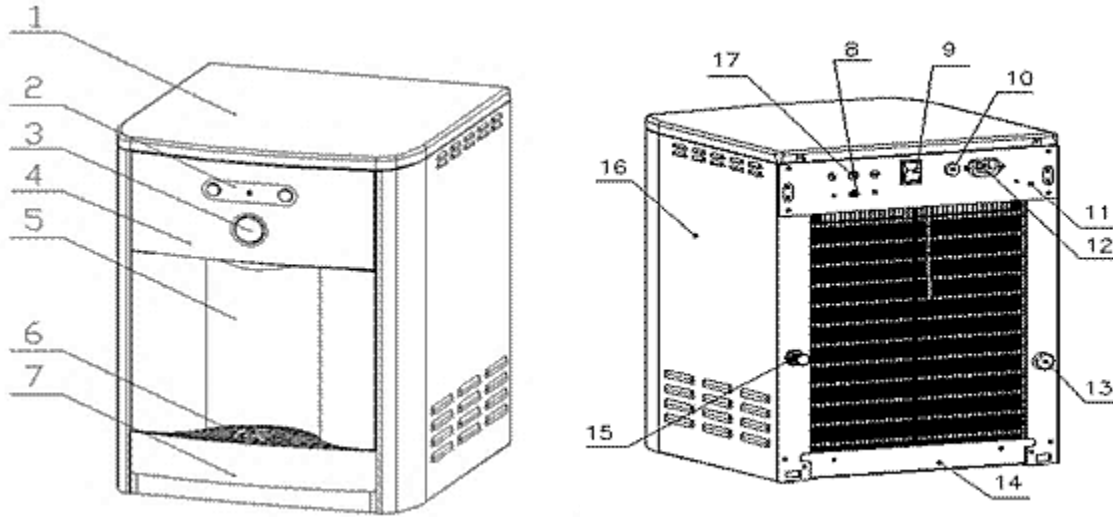

No	Part No	Description	WLUSA Part No.
1	PL-1249CN	Top Cover Charcoal with BioCote®	12-8060
2	LP-7084	Button Label	12-8057
3	PL-1153	Silicon Button Key Mat	12-8056
4	PL-1147-B	Front Hatch Panel Charcoal - UV Inside Logo with BioCote®	12-8051
5	PL-1146	Drip Tray Insert Panel	12-8050
6	PL-1152	Drip Tray Grill with BioCote®	12-8150
7	PL-1156	Drip Tray Body with Waterlogic Logo (Assembly) with BioCote®	12-8055
8	ST-8140	4mm x 10mm Screw	NA
9	EL-5004	Red Heater and Compressor Switch	10-3008
10	EL-5053	Fuse Holder Assembly and Fuse	EL-5053
10a	NA	Fuse (15A, 110V)	NA
11	ST-8216	Back Panel	12-8061
12	EL-5016	Power Line Noise Filter, EMI Filter	10-4013
13	PU-4011	JG Bulkhead Connector Union 1/4" * 1/4" (JG part # PI1208S)	NA
14	ST-8151	Bottom Base Panel	12-3170
15	PU-4028	JG Bulkhead Connector Union 1/4" * 1/4" (JG part # PI1208S)	10-3067
16	ST-8245	Side Panel	12-8062
17	CT-2016	Cold Water Thermostat	12-1101

WL250 TOWER LAYOUT DRAWING with PART NUMBERS

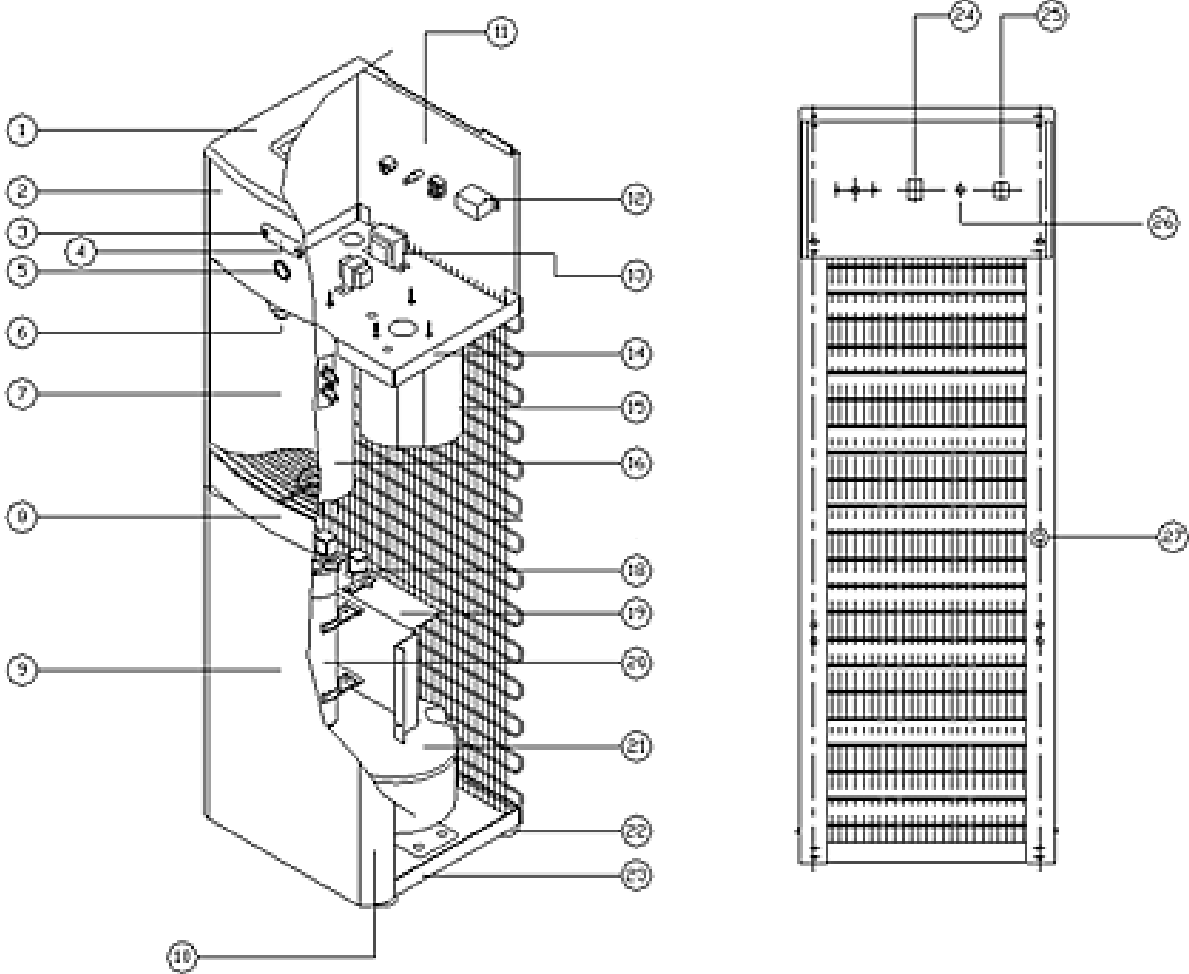

WL250 TOWER LAYOUT DRAWING with PART NUMBERS

No	Part No	Description	WLUSA Part No.	Hot and Cold	Cold Only
1	PL-1150	Top Cover with BioCote®	12-8054	X	X
2	PL-1147-B	Front Hatch Panel Charcoal with UV Logo - BioCote®	12-8051	X	X
3	LP-7084	Button Label Hot and Cold	12-8057	X	
3	LP-7085	Button Label Cold Only	12-8610		X
4	EN-6085	PCB LED Hot and Cold	12-8103	X	
4	EN-6086	PCB LED Cold Only	12-8615		X
5	PL-1153	Silicon Button Keymat Hot and Cold with BioCote®	12-8056	X	
5	PL-1100	Silicon Button Keymat Cold Only with BioCote®	12-8600		X
6	PL-1011-A	Faucet Nipple with BioCote®	10-3048	X	
7	PL-1146	Front Panel for Drip Tray Insert	12-8050	X	X
8	PL-1156	Drip Tray Body Charcoal with BioCote®	12-8055	X	X
9	PL-1149	Front Down Insert Panel	12-8053	X	X
10	PL-1148	Front Down Panel	12-8052	X	X
11	ST-8135	Back Panel Silver	12-8002	X	X
12	CT-2016	Cold Water Thermostat	12-1101	X	X
13	EL-5050	Power Transformer UV 120V/60Hz	12-3245	X	X
14	ST-8136	Upper Front Shelf	12-8003	X	X
15	CT-2029	Cold Tank 4 Liter Assembly with UV Holder	12-4000	X	X
16	HT-3018	Hot Tank Stainless Steel 1.6 Liter (87°C - 189°F)	12-1405	X	
18	PU-4016	Solenoid Valve DC24V 1000mm	12-1500	X	X
19	ST-8138	Filter Bracket	12-8005	X	X
20	N/A	Filter	N/A	X	X
21	CO-9001-A	Compressor	10-2200	X	X
22	ST-8167CN	Rubber Feet	11-2065	X	X
23	ST-8137	Down Base	12-8004	X	X
24	EL-5004	Red Heater and Compressor Switch	10-3008	X	X
25	EL-5016	Socket with EMI Filter	10-4013	X	X
26	EL-5053	Fuse Holder and Fuse 110V/15A	EL-5053	X	X
27	PU-4011	JG Bulkhead Connector Union 1/4" * 1/4" (JG part # PI1208S)	10-3067	X	

WL250 COUNTER TOP MAIN PARTS DRAWING

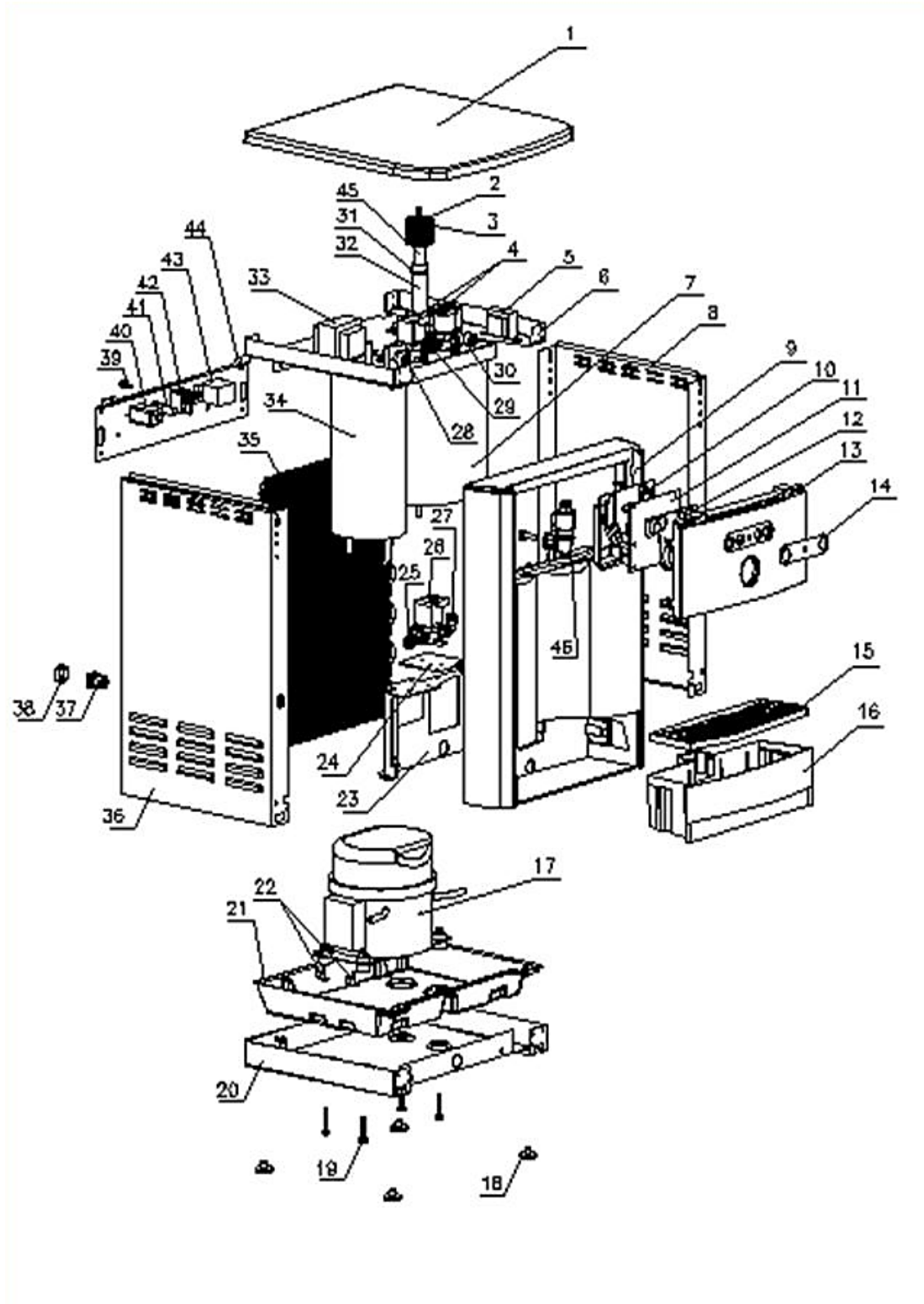

WL250 COUNTER TOP MAIN PARTS LIST

No	Part No	Description	WLUSA Part No.
1	PL-1249CN	Top Cover Charcoal with BioCote®	12-8060
2	CT-2001-B	UV Lamp Fixing Rubber (Silicon)	10-8085
3	PL-1128	UV Lamp Retaining Threaded Nut	12-1210
4	PU-4016	Solenoid Valve DC24V 500 mm	12-1500
5	EL-5006-A	UV Lamp Ballast with Metal Cover	10-3010
6	ST-8150	Upper Base	12-3165
7	CT-2060	UV Cold Tank Assembly 2 Liter	12-3110
8	ST-8245	Side Panel Right	12-8062
9	PL-1146	Front Panel for Drip Tray Insert	12-8050
10	PL-1298	PCB Cover	12-3160
11	EN-6085-A	PCB	12-3115
12	PL-1153	Silicon Button Key Mat with BioCote®	12-8056
13	PL-1147-B	Front Hatch Panel Charcoal with UV Logo with BioCote®	12-8051
14	LP-7084	Button Label	12-8057
15	PL-1152	Drip Tray Grill with BioCote®	12-8150
16	PL-1156	Drip Tray Body with Waterlogic Logo with BioCote®	12-8055
17	CO-9001-A	Compressor (R134a 1/8 HP) 110V / 60Hz	10-2200
18	PL-1251-CN	Unit Rubber Feet	12-3150
19	NA	Bolt M6*30	NA
20	ST-8151	Lower Base	12-3170
21	PL-1294	Leak Tray	12-3155
22	ST-8207-CN	Leak Containment Tray Clip – Sensor 0.5mm	12-3180
23	ST-8152	Filter Bracket	12-3175
24	ST-8244	Leak System Inlet Solenoid Fixing Bracket	12-3195
25	NA	JG Equal Tee Connector ¼" (P10208S)	NA
26	PU-4016	Solenoid Valve DC24V 500 mm	12-1500
27	NA	JG Equal Elbow Connector ¼" (PI0308S)	NA
28	NA	JG Reducing Elbow Connector 5/16" * ¼" (PI211008S)	NA
29	NA	JG Equal Tee Connector ¼" (P10208S)	NA
30	PU-4007	JG Reducing Elbow Connector 5/16" * ¼" (PI211008S)	13-3055
31	CT-2006	O-Ring – Black Quartz Sleeve	10-2500
32	CT-2026	Quartz Sleeve D152mm for 4W Lamp	14-1051

33	EL-5003-A	Power Transformer	12-3117
34	HT-3018-A	Hot Tank 1.6 Liter Stainless (87°C - 189°F)	12-1406
34a	HT-3012	Thermal Overload (105°C - 221°F)	12-1360
34b	HT-3013A	Hot Tank Thermostat	12-1303
34c	ST-0045-L00-00	Thermostat and Overload Metal Cover	12-6900
35	CO-9031	Wire Condenser	12-3100
36	ST-8245	Side Panel Left	12-8062
37	NA	JG Equal Tee Connector ¼" (PI0208S)	NA
38	NA	Plastic Cap for ¼" Bulkhead Fitting	NA
39	ST-8140	Screw 4*10	NA
40	EL-5016	Socket with EMI Filter	10-4013
41	EL-5053	Fuse Holder and Fuse 110V / 15A	EL-5053
42	EL-5004	Red Heater and Compressor Switch	10-3008
43	CT-2016	Cold Water Thermostat	12-1101
44	ST-8216	Back Panel	12-8061
45	CT-2084	UV Lamp 4W – Philips	12-2350
45a	EL-5048	Wire Harness Set	12-8210
46	PL-1011-A	Faucet Nipple with BioCote®	10-2701
46a	PL-1079-BO	Blue Faucet Nipple, with Stainless Steel Gauze	10-3048
46b	CT-2007	Faucet O-Ring	10-2600
Not Shown	CO-9016	Starter Relay for Compressor	10-3003
Not Shown	CO-9015	Thermal Overload (102°C - 221°F)	10-5018

WL250 TOWER MAIN PARTS DRAWING

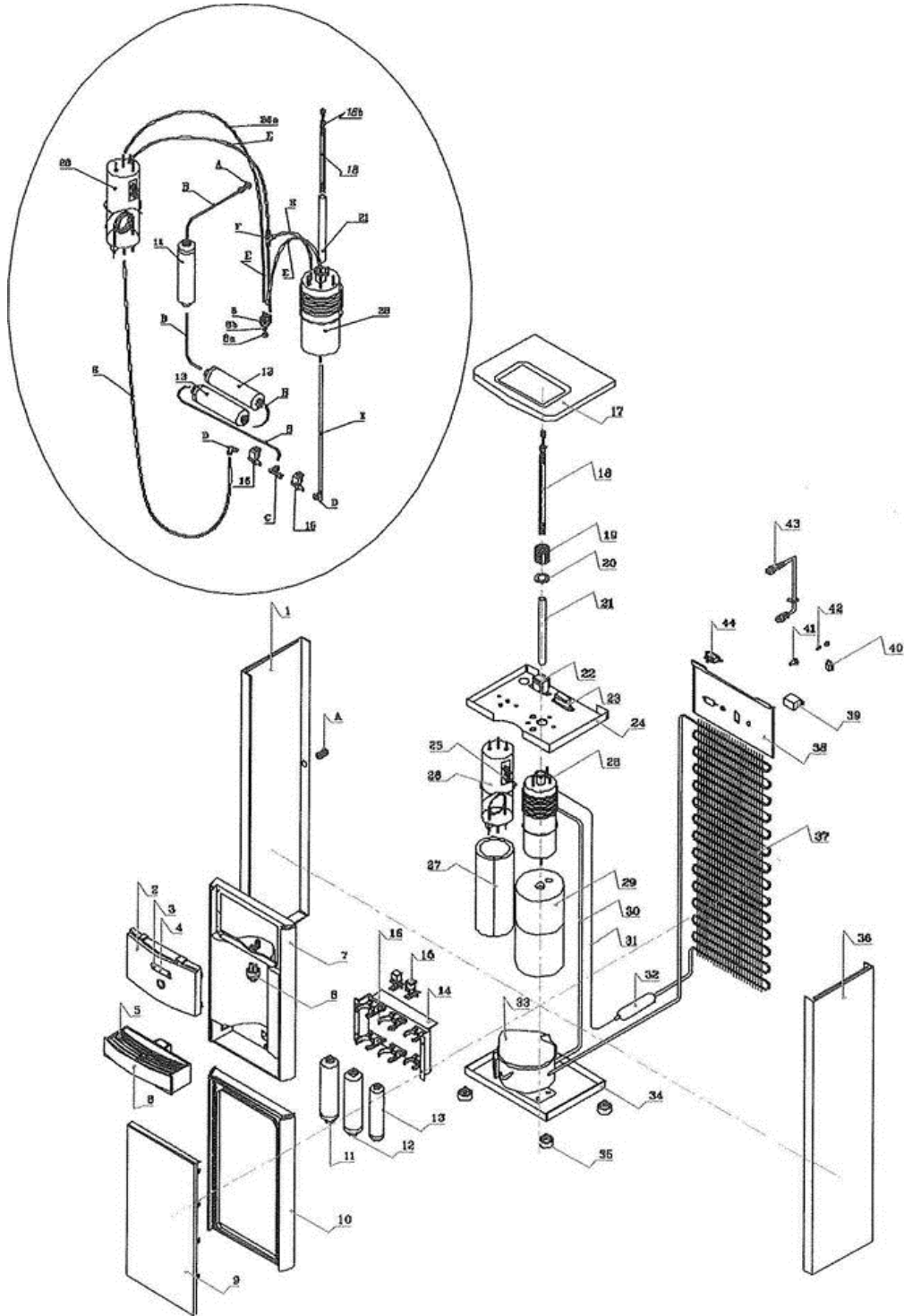

WL250 TOWER MAIN PARTS LIST

NO	Part No	Description	WLUSA Part No
1	ST-8157	Side Panel	12-8000
2	PL-1147-B	Front Upper Panel	12-8051
3	PL-1153	Silicon Button Key Mat	12-8056
4	EN-6085-A	PCB	NA
4a (Not Shown)	LP-7084	Button Label	12-8057
5	PL-1152	Drip Tray Grill BioCote®	12-8150
6	PL-1156	Drip Tray Body with WL Logo	12-8055
7	PL-1146	Front Panel for Drip Tray Insert	12-8050
8	PL-1081-BO	Faucet, White Plastic with SS Inserts	10-2700
8a (Not Shown)	CT-2007	Natural Faucet O-Ring – Silicon White	10-2600
8b (Not Shown)	PL-1079-BO	Blue Faucet Nipple with Stainless Steel Gauze	10-3048
9	PL-1149	Front Lower Insert Panel	12-8053
10	PL-1148	Front Lower Panel	12-8052
11	NA	Sediment Filter, 5 Micron – Recommended	12-2000
12	NA	Carbon Block Filter, 1 Micron – Recommended	12-2001
13	NA	GAC Filter, Taste and Odor Reduction – Recommended	12-2002
14	ST-8138	Filter Bracket	12-8005
15	PU-4016	Solenoid Valve DC24V 1000mm	12-1500
16	PU-4025	Filter Clip, 2 Inch for In-Line Filter	10-3098
16a (Not Shown)	PU-4024	Filter Clip, 2.5 inch for Sediment and Carbon Filters	10-3099
17	PL-1150	Top Cover – Black	12-8054
18	CT-2083	UV Lamp – 8W Assembly	10-2350
18a (Not shown)	NA	UV Lamp Wiring Harness (Included in assembly)	NA
18b (Not Shown)	CT-2001-B	UV Lamp Fixing Rubber	10-3004
19	PL-1128	UV Lamp retaining Threaded Nut	12-1210
20	CT-2006	O-Ring – Black Quartz Sleeve	10-2500
21	CT-2002	Quartz Sleeve for 8W Lamp	10-1400
22	EL-5003-A	Power Transformer UV 120V / 60Hz	12-3117
23	EL-5006-A	UV Lamp Ballast 110V	10-3010
24	ST-8136	Steel Upper Shelf	12-8003
25	ST-0045-L00-00	Hot Tank Supplemental Steel Enclosure	12-6900
25a (Not Shown)	HT-3012	Thermal Overload for Hot Tank, Manual Reset	12-1360
25b (Not Shown)	HT-3013A	Hot tank Thermostat	12-1303
26	HT-3018-A	Hot Tank Assembly 1.6 Liter Stainless with Thermostat Tank (87°C - 189°F)	12-1415

26a (Not Shown)	ST-8120	Hot Tank Mounting Bracket	12-8006
26b (Not Shown)	EN-6042	Hot Tank Power Wire, Red	12-1102
26c (Not Shown)	EN-6044	Thermal Cutout Wire, Connects Hot Tank Thermostat to Hot Tank Overload	12-1306
26d (Not Shown)	HT-3007	Hot Tank Fixing Nut	12-1301
26e (Not Shown)	EL-5048	Wire Harness Set	12-8210
26f (Not Shown)	PU-4064	Silicon Tube 5/16" for Hot Water	10-7040
27	HT-3022	Insulation, Hot Tank, Sidewall	12-8007
27a (Not Shown)	NA	Insulation, Hot Tank, Top Section	NA
28	CT-2060	UV Cold Tank Assembly 2 Liters	12-3110
29	CO-9011	Insulation, 4 Liter Cold Tank	12-1002
30	NA	Intentionally Left Blank	NA
31	NA	Intentionally Left Blank	NA
32	CO-9008	Filter Dryer	12-1001
33	CO-9001-A	Compressor (R134a 1/8 HP) 110V/60Hz	10-2200
33a (Not Shown)	CO-9016	Starter Relay for Compressor	10-3003
33b (Not Shown)	CO-9015	Thermal Overload for Compressor	10-5018
33c (Not Shown)	EN-6025	Ground Wire – Compressor L320mm	10-7095
34	ST-8137	Lower Steel Shelf	12-8004
35	PL-1251-CN	Unit Rubber Feet	12-3150
36	ST-8157	Silver Side Panel with Handle Hole	12-8000
37	CO-9027	Condenser	12-8102
38	ST-8135	Back Panel	12-8002
39	CT-2016	Cold Water Thermostat	12-1101
40	EL-5004	Red Heater and Compressor Switch	10-3008
40a (Not Shown)	EL-5051	Wire Harness Set	12-8107
40b (Not Shown)	EN-6065	Red Switch Wire with UV Lamp Connector	12-1208
40c (Not Shown)	EN-6064	Black Switch Wire with UV Lamp Connector	12-1209
41 & 42	EL-5053	Fuse Holder and Fuse 110V / 15A	EL-5053
43	EL-5001-A	Power Cord – AC USA Molded Black – 120V – 1825 mm	10-3007
44	EL-5016	Power Line Noise Filter, EMI Filter	10-4013
Not Shown	AK-0008-A	UV 3 Minute Timer Board / PCB Hot and Cold	12-8510
Not Shown	AK-0008-C	UV 3 Minute Timer Board / PCB Cold	12-8520
Not Shown	PL-1011-A	Faucet Nipple with BioCote®	10-2701
Not Shown	PL-1013	Blue Faucet Nipple, with Stainless Steel Gauze	10-3048
Not Shown	CT-2007	White Silicon Faucet O-Ring	10-2600

WL250 TOWER WETTED PARTS DRAWING AND PARTS LIST

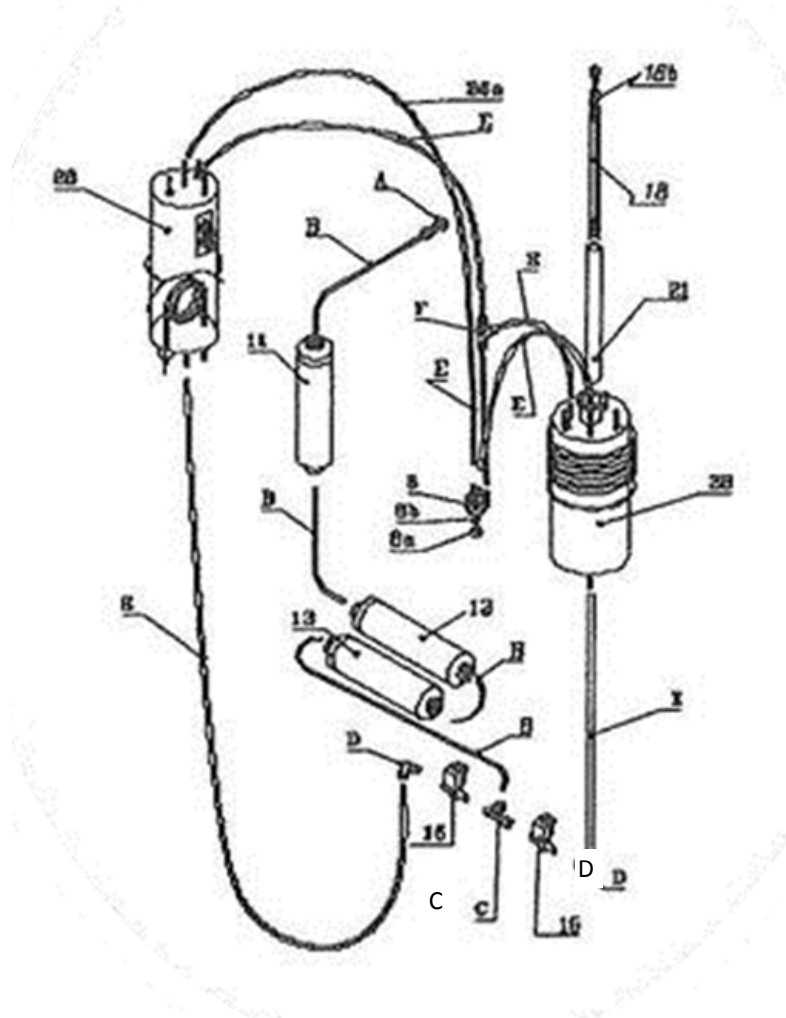

No	Part No	Description	WLUSA Part No.
A	PU-4028	JG Bulkhead Connector Union 1/4" * 1/4" – PI1208S	10-3067
B	PU-4031	JG LLD PE Tube – Blue OD 1/4" – PE-08-BI-1000F-B	NA
C	PU-4008	JG Equal Elbow Connector 1/4" – PI0308S	NA
D	PU-4007	JG Reducing Elbow Connector 5/16" * 1/4" – PI211008S	NA
E	PU-4014	Blue Hose 8mm	10-3062
F	NA	JG Equal Tee Connector 1/4" – PI0208S	NA

WL250 COUNTER TOP ELECTRICAL DIAGRAM

⚠ DANGER! HIGH VOLTAGE ELECTRICAL HAZARD. PCB (Printed Circuit Board) contains High Voltage. Only trained and qualified technicians should attempt live testing.

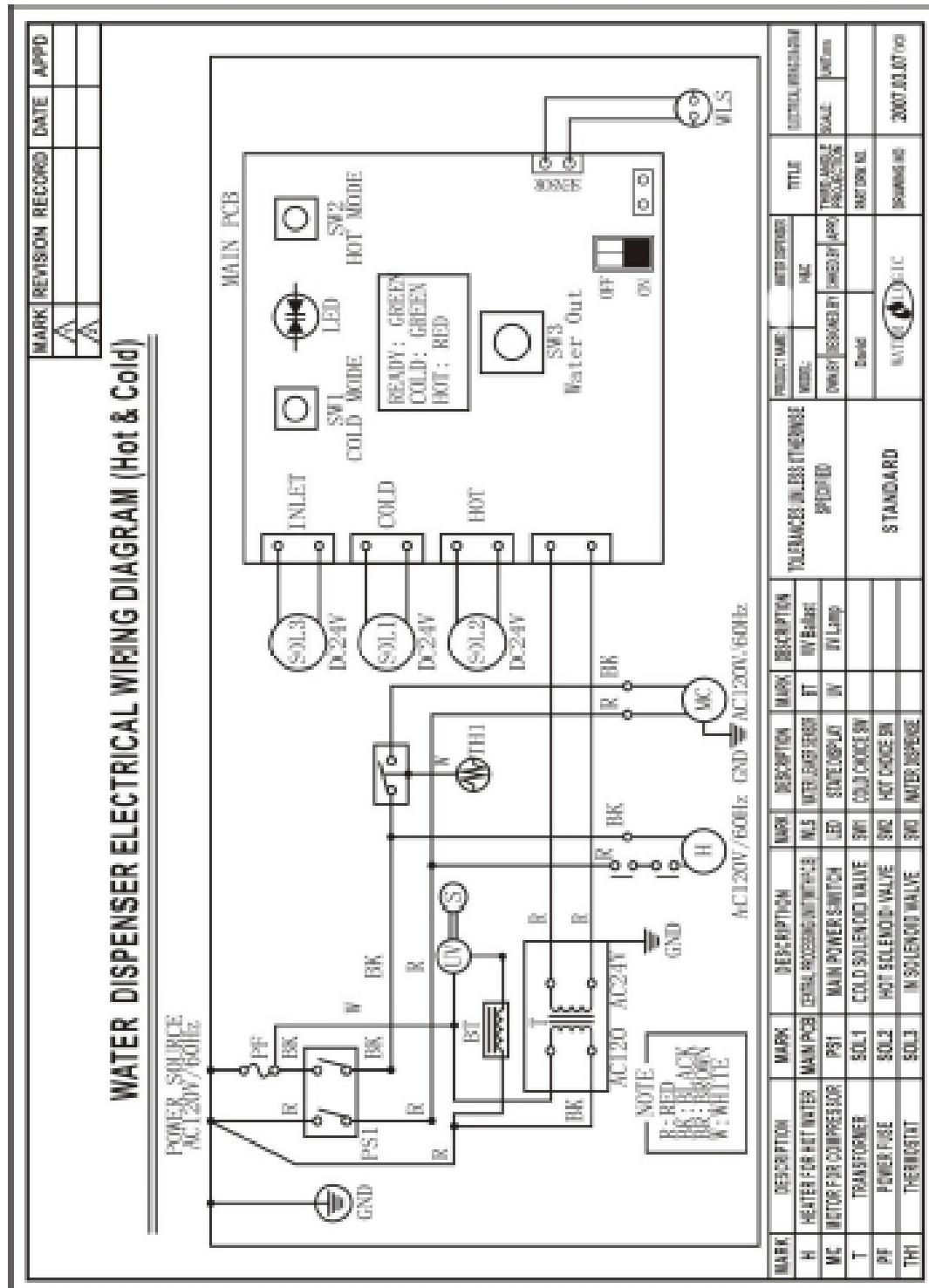

WL250 TOWER ELECTRICAL DIAGRAM

⚠ DANGER! HIGH VOLTAGE ELECTRICAL HAZARD. PCB (Printed Circuit Board) contains High Voltage. Only trained and qualified technicians should attempt live testing.

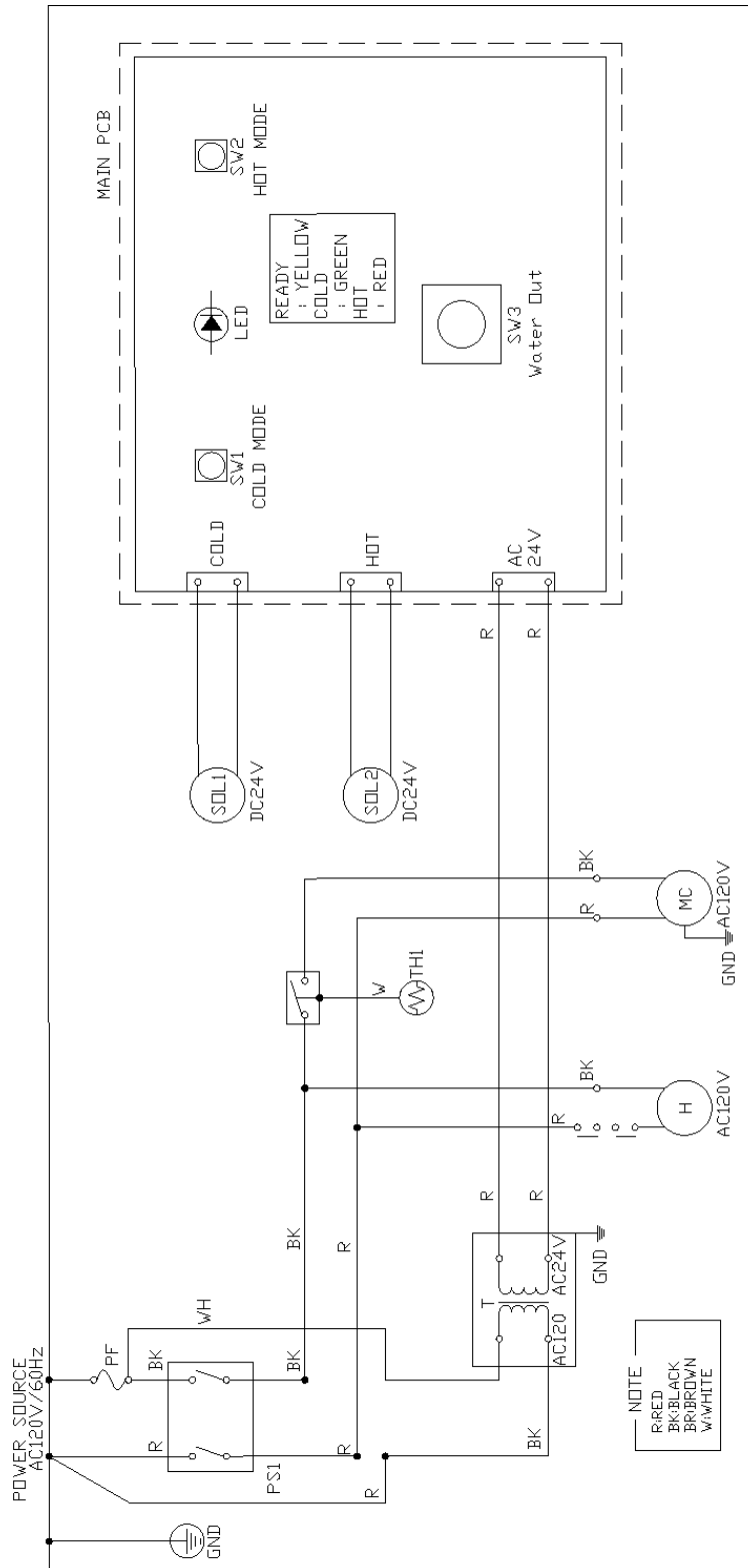

FAULT CODES

FAULT CODE: Red Flashing Light and Audible Alarms are the Leak Detector Alarms for Counter Top Model

Possible Reason	Solution
Water exiting drip tray due to being full	Empty Drip Tray. Remove Top cover and Front Panel prior to drying out inside of the unit.
Leak in WL250 Counter Top	Water is in the bottom of the unit. Open up unit to determine where the leak is. Check for source of leak. Dry out inside of unit.

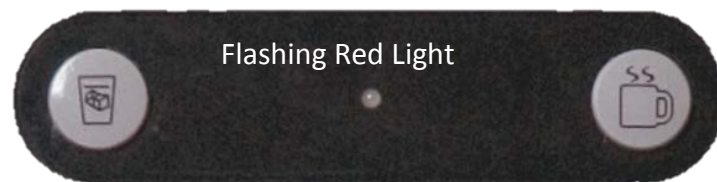

FAULT CODE: No LED Light

Possible Reason	Solution
Power Problem	Check for power disruption.

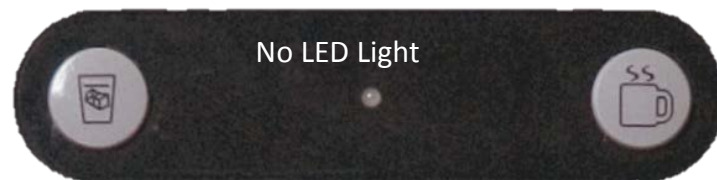

TROUBLESHOOTING

Irregular / Intermittent Dispensing

Possible Reason	Solution
<p>Too much water pressure. Recommend 40 to 60 psi for WL250 to operate properly.</p>	<p>Check water pressure at the inlet bulkhead with a water pressure gauge.</p> <p>Additional method of verification is to turn off water to unit and press the dispense button. Does the solenoid open without water pressure to the unit? Listen for solenoid to activate, not button “click”.</p> <p>Adjust water pressure to 40-60 psi.</p>
<p>Dispensing button is broken on PCB</p>	<p>Check PCB for loose or damaged button. Replace PCB as necessary.</p>

TROUBLESHOOTING

No Water is Dispensing from One Side – Cold or Hot

Possible Reason	Solution
<p>Too much water pressure.</p> <p>Recommend 40 to 60 psi for WL250 to operate properly.</p>	<p>Check water pressure at the inlet bulkhead with a water pressure gage.</p> <p>Additional method of verification is to turn off water to unit and press the dispense button. Does the solenoid open without water pressure to the unit? Listen for solenoid to activate, not button “click”.</p> <p>Adjust water pressure to 40-60 psi.</p>
<p>PCB</p>	<p>Switch the hot and cold wires on PCB (red and blue connections).</p> <p>If water now dispenses from the opposite side, this is an indication that there is a PCB problem.</p> <p>Replace PCB</p>
<p>Solenoid</p>	<p>If both the Water Pressure and PCB have been ruled out, then it is the Solenoid.</p> <p>Replace Solenoid.</p>

TROUBLESHOOTING

Hot Water is not Hot (185° +/- 5° F)

NOTE: The WL250 does NOT have Sleep or Power Saving Mode and the hot water should be a minimum of 185°F under normal operating conditions.

The Hot temperature set point is 185° F and is controlled by a thermostat on the side of the tank.

There is a resettable overload or high limit safety above the thermostat on the side of the tank that will trip to prevent damage to the unit if the tank is dry heated (turned on without water in it).

The WL250 does NOT have Extra Hot capability and the maximum hot temperature is 193°F.

It typically takes 10 minutes for the 500W to heat the 1.6 Liter of room temperature (ambient) water to the 185°F set point.

Possible Reason	Solution
No power to heater elements	<p>Check that the Red Heater and Compressor switch is on.</p> <p>Turn Red Heater and Compressor Switch on. <i>I = ON</i></p> 
Loose or improperly connected wire(s) to the heating element / hot tank.	<p>Visually inspect wire leads going to the hot tank; confirm proper connections to the heating elements.</p> <p>Hot tank life is 3-5 years, depending on usage.</p> <p><i>*Typically dealers swap out the hot tank at site, take back to the shop to repair.</i></p>
Overload Tripped <i>Overload is a safety feature to ensure the tank does not overheat.</i>	<p>Overload will “click” when pushed. The overload is automatically reset when pressed.</p> <p><u>*See Overload Reset Instructions Included in Manual</u></p>
Thermostat or overload “open” on Hot Tank	<p>Turn Power off. Check OHM’s resistance across terminals on each Thermostat and Overload separately.</p> <p>Good components will indicate a closed circuit or zero OHM’s on the meter.</p> <p>Replace components as necessary.</p>
Heating Coil not Working	<p>Turn Power off; Drain hot tank; Use multi-meter to check heater element for approximately 26 OHM’s resistance.</p> <p>Hot tank must be empty if you are checking for continuity.</p> <p>Replace Hot Tank as necessary.</p>

TROUBLESHOOTING

Hot Water or Steam Coming out of both the Faucet and Vent Hole

Possible Reason	Solution
Improper tubing attachment from the hot tank to faucet or vice versa.	Check that the tubing is connected from tank outlets to correct faucet attachments. Connect tubing to outlets as needed.

TROUBLESHOOTING

Hot Water Drip out of Faucet

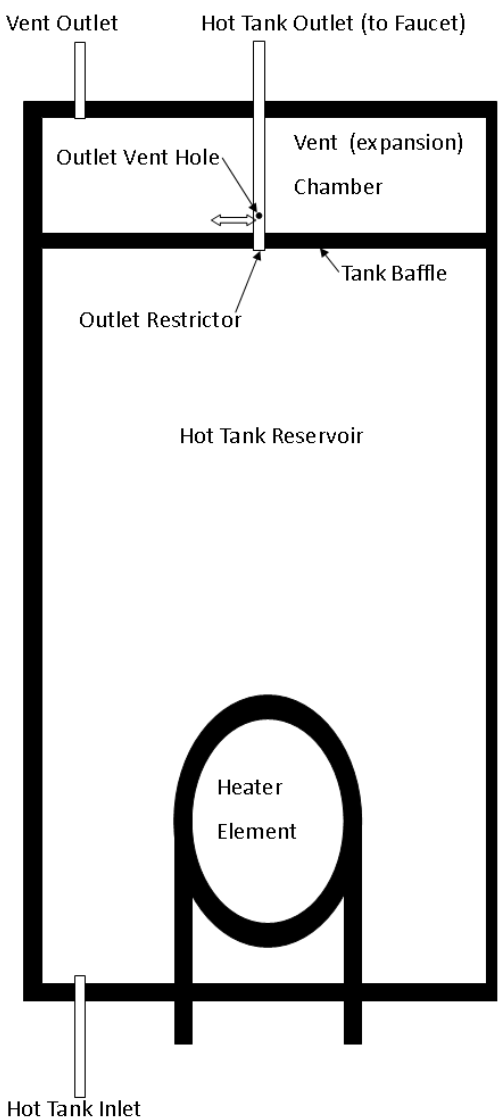
Possible Reason	Solution
<p>Small Outlet Vent Hole susceptible to scale build up.</p>	<p>Descale Tank. Descale Instructions are available as a separate section of this Manual and see the "How to Descale your Hot Tank" instructional video on the Partner Area of the new Waterlogic.com website for more information.</p>
	<p>All Waterlogic Hot Tanks have a built in Vent or Expansion Chamber in the top of the tank except for WL270 (GF) units.</p> <p>The Vent Chamber allows for expansion of the water when it is heated.</p> <p>The chambers are separated by a welded-in tank baffle.</p> <p>Water always flows into the bottom of the tank and out the top to the faucet.</p> <p>The hot tank outlet tube has a restrictor in its base. This ensures the reservoir is always full by allowing more water in than out.</p> <p>There is a small hole in the side of the tank outlet tube that allows air and water to pass into the vent chamber as it is heated.</p> <p>Water in the vent chamber is suctioned back through the outlet tube vent hole when water is dispensed.</p> <p>Expansion of water as it is heated in the reservoir will push the water out the faucet when the outlet tube vent hole becomes plugged with debris or scale.</p> <p>The small Outlet Vent Hole is susceptible to scale build up and is a key indicator that descaling is required.</p> <p>It is critical to descale the hot tank through the vent line and outlet line on a regular basis to prevent this problem.</p> <p>Descaling through the inlet and/or outlet lines only will not clean the vent chamber and outlet vent hole properly.</p>

TROUBLESHOOTING

Hot Water Coming out of Faucet Vent Hole

Possible Reason	Solution
Improper tubing attachment from the tank to faucet or vice versa.	Verify tubing is connected properly from tank outlets to correct faucet attachments.
Hot Tank outlet hole is scaled over.	Inspect and descale or replace hot tank.
Expansion chamber is not sealed properly.	Replace the Hot Tank.

TROUBLESHOOTING

Restricted Flow of Hot Water

Possible Reason	Solution
Partially closed water supply valve to the unit.	Open water supply valve.
Hot Tank outlet hole is scaled over.	Remove outlet tube from hot tank to faucet. Add descaler to hot tank.
Tubing is creased or has a “kink” in it.	Inspect and replace tubing as necessary.
Faucet nipple screen mesh has obstruction(s)	Unscrew faucet nipple from faucet and remove any obstruction(s) from screen mesh.
Exhausted Filter	Replace the Filter
Solenoid connection to the Display PCB	Turn power off; unplug the unit and visually inspect solenoid connections into the Display PCB. Verify the soldering points on connections are secure into the board. Remove the PCB to inspect the front of the board.
Solenoid Valve is Malfunctioning	Inspect valve components for proper function. Replace as necessary.

TROUBLESHOOTING

Cold Water is not Cold (41° +/- 5° F)

Possible Reason	Solution
No power or refrigeration elements	<p>Check that the Red Heater and Compressor switch is on.</p> <p>Turn Red Heater and Compressor Switch on. <i>I = ON</i></p> 
<p>Tank has run out of cold water.</p> <p><i>Cold tank capacity is 4 liters for Tower and 2 liters for Counter Top.</i></p>	<p>Wait for cold tank to chill water to temperature prior to dispensing more cold water.</p> <p>A greater capacity of Waterlogic Water Systems is available.</p>
Cold Water Thermostat	Check continuity of thermostat with multimeter. Replace thermostat as required.
Refrigerant has run out	Run compressor for at least ten minutes. If condenser is not warm then refill the refrigerant.
Compressor problem	If compressor is not running, repair or replacement is needed.

TROUBLESHOOTING

Steady Drip Out of Faucet

Possible Reason	Solution
Debris in Solenoid	Inspect Solenoid for debris and clean out as needed.

TROUBLESHOOTING

Dispenses Hot and Cold Water at the Same Time

Possible Reason	Solution
<p>Hot or Cold solenoid is stuck open.</p>	<p>Remove top cover.</p> <p>Check Hot Solenoid: Dispense cold water and visually inspect tubing for water flow from both tanks.</p> <p>Check Cold Solenoid: Disconnect elbow from outlet of cold solenoid. Select hot water and dispense (quickly releasing dispensing button to avoid much water coming out of cold solenoid).</p> <p>Replace solenoid as necessary.</p>

TROUBLESHOOTING

No Cold Water Available

Possible Reason	Solution
Closed Water Supply Valve	Open the Water Supply Valve
Cold Water Solenoid Valve malfunction	Inspect the valve components for proper functionality.
Red Heater and Compressor Switch on unit is off.	Turn Red Heater and Compressor Switch on. <i>I = ON</i> 
Loose connection(s) on the Display PCB	Turn power off; unplug the unit and visually inspect solenoid connections into the Display PCB. Verify the soldering points on connections are secure into the board. Remove the PCB to inspect the front of the board.
Exhausted Filter	Replace filters as needed.

TROUBLESHOOTING

Water is Not being Heated or Chilled

Possible Reason	Solution
<p>Red Heater and Compressor Switch on unit is off.</p>	<p>Turn Red Heater and Compressor Switch on. <i>I = ON</i></p> 

TROUBLESHOOTING

No Cold or Hot Water Will Dispense from Unit

Possible Reason	Solution	
Closed water supply valve	Open the water supply valve.	
The unit is not properly plugged into electrical outlet	Check electrical outlet connection, or for blown circuit breaker.	
Red Heater and Compressor button on unit is in the off position	Turn Red Heater and Compressor switch on. <i>I = ON</i>	
15 Amp Fuse Blown	Replace the 15 Amp Fuse as needed.	
Water is present in the bottom tray, causing the leak detection to trigger. <i>*Leak Detection is on Counter Top model only.</i>	Remove the top cover and front panel. Tip the unit slightly to drain, dry bottom tray completely.	
Hot and Cold Solenoid connections into the Displace PCB are loose.	Turn power off; unplug the unit and visually inspect solenoid connections into the Display PCB. Verify the soldering points on connections are secure into the board. Remove the PCB to inspect the front of the board.	
Exhausted Filter	Replace filters as needed.	

TROUBLESHOOTING

Cold Water Dispenses from Faucet and Vent Outlet Simultaneously

Possible Reason	Solution
Improper tubing attachment from the tank to faucet or vice versa	Verify tubing is connected properly from tank outlets to correct faucet attachments.
Scale has formed inside cold tank outlet tube.	Remove cold water outlet tube from tank to faucet. Pour some scale remover into cold tank.
Expansion chamber in Cold Tank is not sealed properly.	Replace Cold Tank.



TROUBLESHOOTING

Compressor Runs But Does Not Chill

Possible Reason	Solution
Condenser is dirty	Clean the condensing coil of any obstructions or dust.
Reduction of airflow into unit.	Make sure unit is not under minimum ventilation requirements (2 to 4 inches).
Compressor is running very hot.	Low or lost refrigerant. Refrigerant recharge required.

TROUBLESHOOTING

Compressor is Not Running

Possible Reason	Solution
<p>Red Heater and Compressor Power Switch button on unit is in the off position</p>	<p>Turn Red Heater and Compressor Power Switch on. <i>I = ON</i></p> 
<p>Compressor Starting Circuit</p>	<p>Turn Red Heater and Compressor Power Switch off. <i>O = OFF.</i></p> <p>Remove the compressor cap on side of the compressor;</p> <p>Disconnect the black and red terminal connectors;</p> <p>Inspect the starter and overload relay for any defects.</p> <p>Replace components(s) as needed.</p> <p>Turn Red Heater and Compressor Power Switch on <i>I = O</i> and retest compressor operation.</p> 

TROUBLESHOOTING

Small Amount of Water Periodically Dispenses from Faucet Automatically

Possible Reason	Solution
Cold or Hot Water solenoid valve malfunction	Inspect valve components for proper function. Replace as necessary.
Obstruction in solenoid housing is preventing proper sealing of component.	<p>Pre-determine whether water being dispensed is hot / cold. Isolate the water supply; push the DISPENSE button to release the line pressure, and remove the coil affixed to the solenoid stem.</p> <p>Remove the stem from the solenoid housing and allow water from the tank to flush out the contaminant(s).</p>

TROUBLESHOOTING

Dispense Buttons Stick

Possible Reason	Solution
Dirt or Foreign material is filling the gap around the push-buttons.	Inspect the push buttons and clean surrounding area. Inspect faucet assembly inside the unit and clean as necessary.

TROUBLESHOOTING

Run On

“Run On” or “Carry On” is present in all Waterlogic pressure fed units without outlet solenoids.

“Run On” is defined as the amount of water that continues to dispense out of the faucet after releasing the dispense button.

Run On exists because the tanks pressurize as water is being dispensed. Every Waterlogic tank has an outlet restrictor to ensure the tanks remain full of water and water is controlled as it is released to the faucet. The inlet solenoid controls flow into the tanks. The tanks will “depressurize” once the dispense button is released the inlet solenoid closes. A small amount of water will “Run On” through the faucet as the tank depressurizes to atmospheric conditions.

Typical “Run On” is 2-3 seconds.

“Run On” can be reduced by installing a pressure limiting device.

The amount of inlet or supply pressure directly impacts the amount of “Run On” as quantified below.

WLCP Lab Testing of Rn On 7-31-2013				
Pressure	Pressure	Time	Flow Rate	Run On
Static PSI	Dynamic PSI	4 Liters	l/min	Seconds
68	40	61	2.9508197	3
50	30	72	2.5	2.5
32	20	92	1.956217	2
Pressure measured at inlet line to unit. Static with unit closed. Dynamic with unit dispensing cold water.				
No filters were installed in unit.				



WATERLOGIC MANUFACTURED WATER TREATMENT SYSTEM LIMITED WARRANTY **UNITED STATES AND CANADA ONLY**

Waterlogic water treatment systems are guaranteed to the original purchaser to be free of defects in materials and workmanship for a period of three (3) years from the date of purchase, but in no event longer than forty-eight (48) months from the date of manufacture. Waterlogic Commercial Products, LLC ("Waterlogic") based in the U.S.A. and its affiliated companies are not liable for any cost of removal, installation, transportation, or any other charges which may arise in connection with a warranty claim.

This warranty does not cover damage or wear to products caused by abnormal operating conditions, accident, abuse, misuse, unauthorized or improper alteration or repair, damage caused by or resulting from shipping or accident, damage caused by hot water, freezing, flood, fire, or acts of God. The effects from chlorine corrosion, scaling and normal wear are specifically excluded from this warranty. This warranty does not cover products used outside the countries where the unit was purchased, and does not cover products that were not installed in accordance with Waterlogic printed installation and operating instructions obtained in training or from www.waterlogic.us. Failure to follow all instructions for operation and maintenance voids the warranty. This warranty is not transferable.

To obtain warranty repairs or replacement, you must obtain a Return Authorization from Waterlogic. To obtain a Return Authorization, you must submit a Return Authorization form with supporting documentation to Waterlogic for evaluation. The form is available at www.waterlogic.us. Supporting documentation must include, but is not limited to; proof of purchase, installation date, failure date, and supporting installation and maintenance data. After you submit a Return Authorization form and supporting documentation, Waterlogic will determine whether a reasonably apparent defect in materials or workmanship covered by this limited warranty exists. If Waterlogic determines the claimed defect is covered by this warranty, Waterlogic will, at its sole discretion, determine whether to correct the defect or replace the unit, free of charge to you. If Waterlogic determines that the unit should be returned for warranty service, Waterlogic will approve of return in writing and will issue a Return Authorization which you must obtain prior to shipping the product. You are responsible for the cost of freight in to Waterlogic.

Waterlogic and its affiliated companies hereby limit the duration of any and all implied warranties to a maximum period of three (3) years from the date of purchase including, but not limited to, the implied warranties of merchantability and fitness for a particular purpose. Some states do not allow limitations on how long an implied warranty lasts, so the above limitation may not apply to you. Consequential and incidental damages are not recoverable under this warranty. Some states do not allow the exclusion or limitation of incidental or consequential damages, so the above limitation or exclusion may not apply to you.

This warranty gives you specific legal rights and you may also have other rights which may vary from state to state.

New Warranty Policy issued by Waterlogic Commercial Products LLC, USA - January 10, 2014

Waterlogic Commercials Products LLC
11710 Stonegate Circle
Omaha, NE 68164

Tel: (800) 288-1891
Website: waterlogic.us